

Transportation Safety Board
of Canada



Bureau de la sécurité des transports
du Canada

**RAILWAY INVESTIGATION REPORT
R11D0099**



NON-MAIN-TRACK DERAILMENT

**AGENCE METROPOLITAINE DE TRANSPORT
COMMUTER TRAIN NO. 805
MILE 73.84, SAINT-HYACINTHE SUBDIVISION
MONTRÉAL, QUEBEC
09 DECEMBER 2011**

Canada

The Transportation Safety Board of Canada (TSB) investigated this occurrence for the purpose of advancing transportation safety. It is not the function of the Board to assign fault or determine civil or criminal liability.

Railway Investigation Report

Non-main-track Derailment

Agence Métropolitaine de Transport
Commuter Train No. 805
Mile 73.84, Saint-Hyacinthe Subdivision
Montreal, Quebec
09 December 2011

Report Number R11D0099

Summary

On 09 December 2011, Agence Métropolitaine de Transport commuter train No. 805, composed of 2 locomotives (one at each end of the train) and 9 bi-level passenger coach cars, was travelling westward at 11 mph when the lead locomotive, which had been in service for approximately 2 weeks, and one coach derailed as they were entering Track 22 in Central Station, Montreal, Quebec. Evacuation of the 1400 passengers from the train was facilitated as the lead portion of the train had stopped adjacent to the passenger platform. There were no injuries.

Ce rapport est également disponible en français.

Other Factual Information

On 09 December 2011, Agence Métropolitaine de Transport (AMT) train No. 805 (the train), a regularly scheduled commuter train, departed Mont-Saint-Hilaire, Quebec, at 0700¹ westward en route to Central Station in Montréal, Quebec (Figure 1). The crew consisted of a locomotive engineer and a conductor. Both crew members were qualified for their respective positions, met fitness and rest standards, and were familiar with the subdivision.

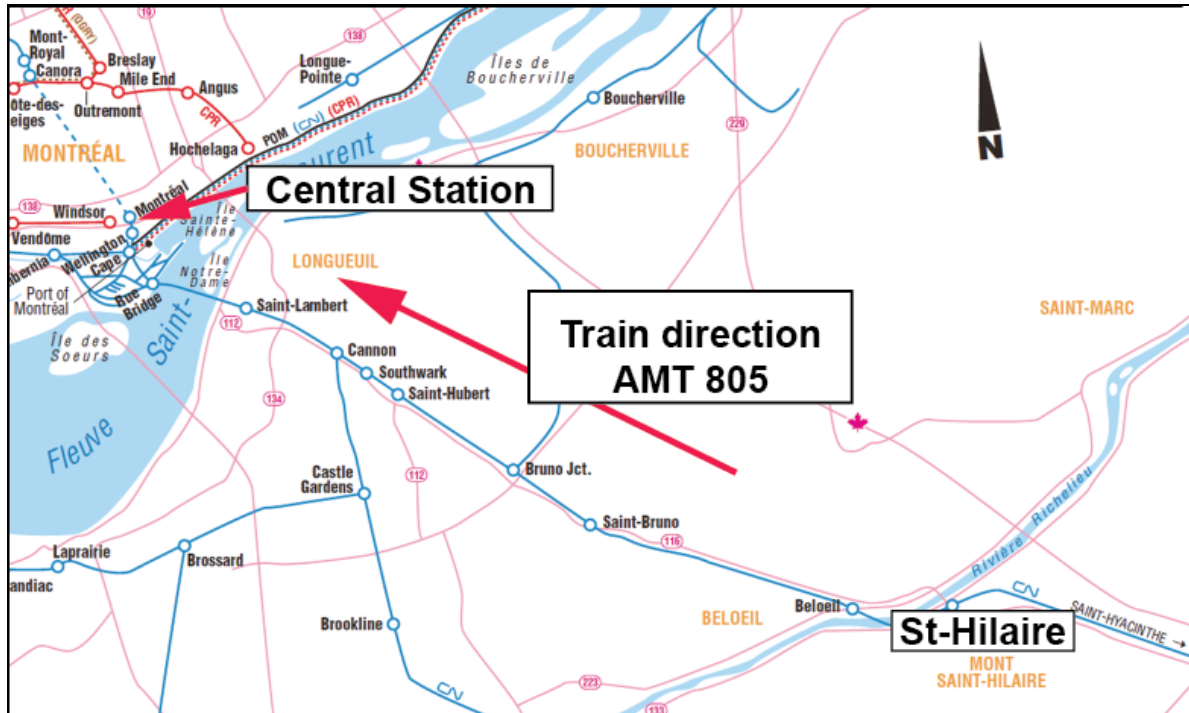

Figure 1. Map of the derailment location (Source: Railway Association of Canada, *Canadian Railway Atlas*)

The trip from Mont-Saint-Hilaire was without incident. At approximately 0747, just before the train entered Central Station, the locomotive engineer shut down the power on the lead locomotive as per normal operating procedure.² The locomotive engineer, positioned in the lead locomotive, was using the power of the rear locomotive to propel the train. The air brakes in the train consist were operative, but were not being used. The throttle had been placed in the idle position during the approach to the station.

As the lead portion of the train was exiting an 11.75° left-hand curve (in the direction of train travel) entering the station platform area on Track 22 (Figure 2) at 11 mph, there was an unusual jolt and the locomotive engineer made an emergency application of the train air brakes. When

¹ All times are Eastern Standard Time.

² The lead locomotives are shut down before entering the underground terminal to minimize exhaust fumes.

the train stopped, the crew determined that the lead locomotive (AMT 1352) and the first coach (AMT 3000) had derailed and had come to rest against the concrete boarding platform that was on the south side of the track.

The passengers were instructed to move to the head end of the train where they were able to egress normally onto the Track 22 boarding platform. There were no injuries.

The temperature was 2°C.

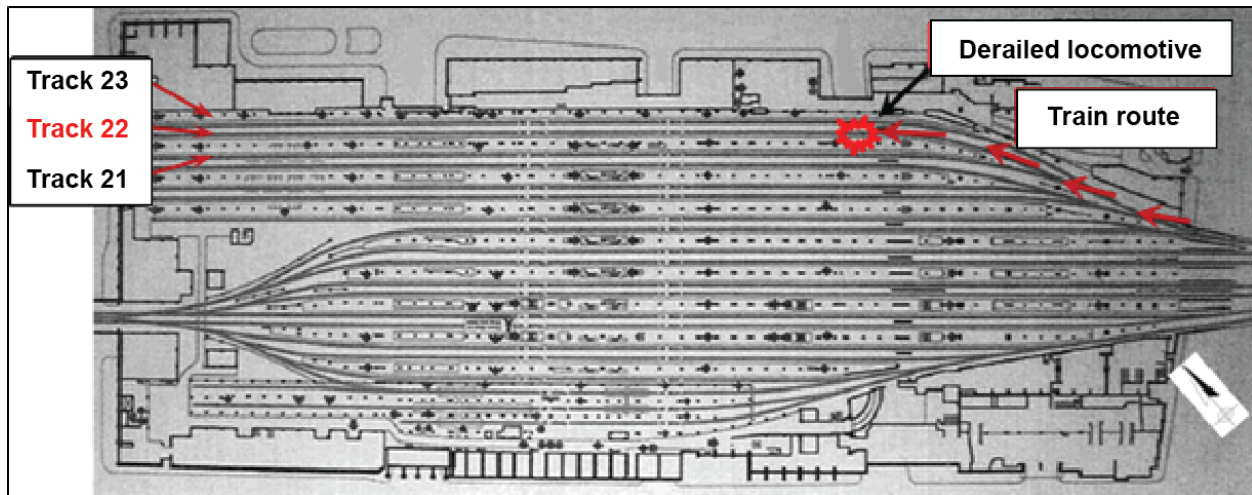

Figure 2. Schematic of track diagrams of Central Station (Source: CN)

Site Information

Central Station is located at Mile 74.25 at the end of the Canadian National (CN) Saint-Hyacinthe Subdivision, which originates at Sainte-Rosalie, Quebec. Central Station is Canada's second busiest train station. It is an underground terminal located in downtown Montréal and consists of 20 tracks used almost exclusively by AMT, VIA Rail Canada Inc. (VIA), and Amtrak for commuter and intercity passenger travel. Train movements within Central Station are controlled by the Centralized Traffic Control system authorized by the *Canadian Rail Operating Rules* and supervised by a rail traffic controller located in Montréal.

A concourse level is located above the station tracks. There are concrete platforms situated on one side of each track for passenger boarding. Passengers can access the boarding platforms from the concourse level by use of stairs and escalators. Some of the tracks, including Track 22, are dead-end tracks that are equipped with a stopping post (bumper) at their west end. Lighting is concentrated mainly on the passenger boarding platform areas. Secondary lighting comes from the many dwarf signals throughout the station and a minor amount of natural light from the eastern entrance.

The lead locomotive stopped approximately 440 feet west of the start of the boarding platform of Track 22. The trailing wheel set of the lead truck of the lead locomotive was derailed to the north side of the track. The other 3 wheel sets of the locomotive had their south wheels derailed

inside the gauge. On the derailed coach, the lead wheel set of the lead truck also dropped inside the gauge.

The first impact marks were observed on a rail joint on the south rail located approximately 200 feet west of the start of the boarding platform and 10 feet west of the end of the curve. Further west, the south rail was rolled to the field side and had been displaced laterally outward in some places by approximately 10 inches (Photo 3). Marks were observed on the inside of the rails along the web and base of the south rail, on the tie plates, as well as on the ties, up to the front of the lead locomotive. The north rail had remained in place. The spikes on the gauge side of the north rail at the end of the curve were raised by approximately $\frac{3}{4}$ to 1 inch.



Photo 1. Curve approaching the boarding platform



Photo 2. Marks on rail joint in south rail



Photo 3. Lateral displacement of south rail



Photo 4. Ballast condition

Train Information

The train consisted of 2 recently acquired Bombardier Transportation (BT) dual-powered locomotives that is AMT 1352 at the head end of the train and AMT 1353 at the tail end and 9 bi-level passenger cars. The train weighed approximately 980 tons and was about 910 feet long.

Locomotive AMT 1352 was delivered to AMT in July 2011. After final testing and commissioning, it was inspected by Transport Canada (TC) on 25 November 2011. It was placed in revenue service on 28 November 2011, approximately 2 weeks before the accident. Since its implementation date, the locomotive had acquired approximately 1070 miles of service for AMT, mostly on the Saint-Hilaire line.

The train received a pre-service inspection and No. 1 brake test on the morning of the accident in Mont-Saint-Hilaire. No defects were observed.

The new locomotives had operated in Central Station 33 times, namely 15 times on Track 21, 5 on Track 22, 8 on Track 23, and the remaining on other tracks.

Equipment Acquisition – AMT

As a result of increased ridership and expansion plans, AMT received funding approval from the Province of Quebec to acquire 160 passenger cars and 20 dual-powered locomotives from BT. Technical specifications for the new equipment were prepared in 2007, the contract was granted in August 2008 and the new equipment started arriving in Montreal in June 2011. The new equipment was used to supplement existing AMT equipment.³ To save on the procurement cost, the locomotives were part of a joint tender with New Jersey Transit (NJ Transit).

Since 2007, numerous meetings have been held between AMT and CN, as well as with Canadian Pacific Railway (CPR), to identify and address issues related to the commissioning of the new equipment. AMT met with the railways during the preparation of the technical specifications, during construction, and during testing. Invitations were extended to the railways by AMT to participate in the inspection of the locomotive assembly in Germany, to become familiar with the locomotive equipment upon arrival at NJ Transit, and to participate during testing in Pueblo, Colorado.

AMT and TC representatives examined the new locomotives during manufacturing in Germany. A new locomotive was shipped to the Association of American Railroads (AAR) Transportation Technology Center near Pueblo. It underwent testing in a North American

³ When the orders are completely filled, passenger capacity for AMT trains will increase by 70% and will allow the retirement of some of the older equipment.

environment over a period of 6 months. CN and CPR crews who would be operating the new locomotives on the AMT trains attended training classes in Montréal.

Locomotive Characteristics

The dual-powered locomotive was built to comply with AAR and American Public Transportation Association Manual of Standards and Recommended Practices, as well as Federal Railroad Administration (FRA), TC, and Province of Quebec requirements (including environmental and emission prerequisites). It was designed to operate safely at speeds up to 125 mph ⁴ with up to 6 inches of cant deficiency. ⁵ It underwent American Public Transportation Association Manual of Standards and Recommended Practices static truck equalization testing (APTA SS-M-014-06) and exceeded its requirements. Technical specifications of the dual-powered locomotive are listed as follows:

Table 1. Locomotive specifications

Overall length	71.5 feet	Wheel type	Class B (110-inch wheelbase)
Gross weight	281 040 pounds ⁶	Wheel profile	AAR - 1:40 taper ⁷
Number of axles	4 (all powered)	Max design speed	125 mph (80 mph on AMT)
Approx. weight/wheel	35 125 pounds	Brakes	Disk & Tread + Dynamic
Classification	ALP-45DP	Operating mode	Electric or diesel

The locomotive truck arrangement was based on a proven BT design used extensively since 1980. Unlike many North American locomotives, the car body of the locomotive is not seated on a bolster. Rather, the car body is supported on each truck by 4 helical Flexicoil springs, with outer and inner coils. These springs deflect vertically under the locomotive weight, and they are sheared laterally as well as longitudinally during truck rotation to help the truck return to its normal orientation upon exiting a curve (Figure 3).

⁴ Maximum operating speed was 80 mph on AMT.

⁵ The amount of superelevation that needs to be added for a movement to achieve balance speed

⁶ The gross vehicle weight of the new locomotive is approximately 7% heavier than the previously used type of locomotives.

⁷ Wheel tread taper is the slope or the conicity of the wheel tread. Increasing the taper (for example, from 1:40 to 1:20) can improve the ability of the wheel set to steer in high-degree curves, and reduce the lateral loads. However, this increases the possibility of wheel set hunting at elevated speeds.

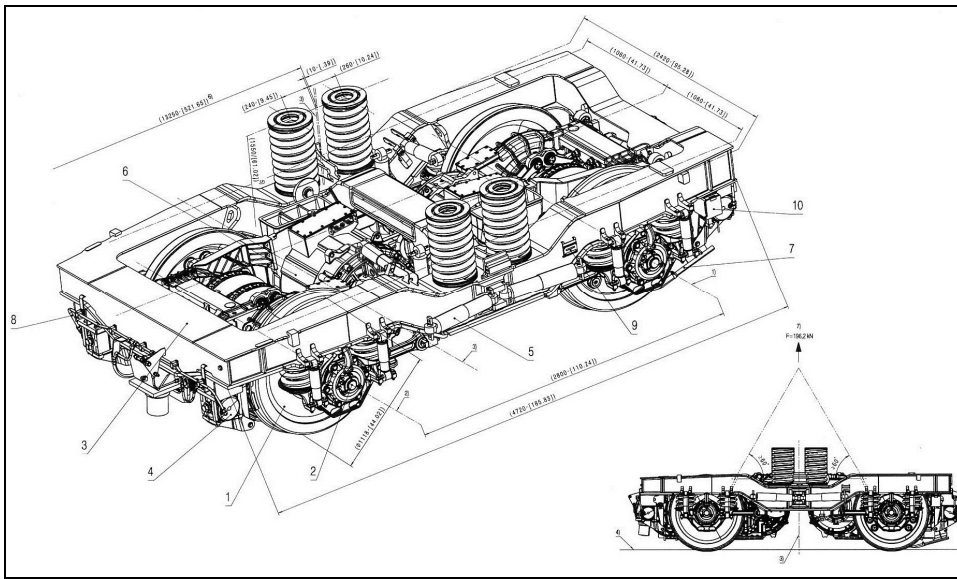

Figure 3. Figure 3. Locomotive ALP-45DP truck arrangement (Source : Bombardier Transportation)

There are over 1000 BT locomotives in service worldwide with a similar truck arrangement. Some of them have axle loads up to 35 tons and have been operating heavy-haul in Europe since 2000. However, most of them have a lighter axle load than the ALP-45DP.

Approximately 60 of these locomotives (type ALP-46), several of which were manufactured since 2002, are in service for NJ Transit. Their weight is approximately 207 000 pounds. Other bolsterless passenger locomotives (type P42-DC and PL-42), operating on Amtrak, NJ Transit, and VIA for more than 10 years, have a gross operating weight ranging between 282 000 and 295 000 pounds.

On 20 December 2011, BT personnel conducted a teardown inspection of AMT 1352 in AMT shops in Pointe-Saint-Charles, Quebec, in the presence of TSB investigators. During this inspection, the mechanical characteristics of the locomotive were compared against the manufacturer's specifications. Nothing abnormal was noted. The quality-control documents from the spring manufacturer were also examined. The spring material and related test requirements were found to meet BT specifications.

Particulars of the Track

Track 22 starts at a No. 8 special turnout. It consisted of a 270-foot left-hand curve, followed by approximately 1000 feet of tangent track ending at a stopping post. The curved portion started approximately 75 feet east of the beginning of the boarding platform, ending 195 feet further west. The track structure consisted of 39-foot jointed rail. The south rail was Dominion

100-pound ARAA HF 1939 (head-free).⁸ The north rail consisted of 100-pound ARAA standard rail followed by 100-pound head-free rail. The transition to head-free rail occurred approximately 60 feet before the end of the curve. The ties were No. 2 hardwood, spaced 18 inches centre to centre, and were in fair condition (Appendix A for tie requirements).

The tie plates used to secure the rail in the derailment area were of a different type and vintage, due to spot maintenance that had occurred over the years. There were 3 types of tie plates: 10-inch, 11-inch, and 14-inch. The 10-inch tie plates were of a unique design, identified with markings Y-1939 CNR. This type was original to the construction of Central Station. The 11-inch and 14-inch were standard double-shouldered tie plates.

The 14-inch tie plates were used under the ARAA standard rail in the north side of the curve. They were secured with 6 spikes per tie plate. A mixture of 10-inch and 11-inch tie plates was used in the remaining section of the track. There was a cluster of 10-inch tie plates in both rails at the end of the curve (photos 5 and 6). There was a 1/8-inch gap between the tie-plate shoulders and the base of the rail.



Photo 5. Locations of 10-inch tie plates with round spikes, indicated by red arrows – south rail

⁸ Head-free rail has a different head section as compared to standard rail. The rail head is not square and its sides are tapered. This type of rail is rarely used, but can still be found on some low traffic density tracks.



Photo 6. Locations of 10-inch tie plates with round spikes, indicated by red arrows – north rail

The 10-inch tie plates were secured with 4 round spikes and 2 lugs. The 11-inch tie plates were secured with 2 spikes in the tangent and a minimum of 3 spikes in the curved section. Many of the 11-inch tie plates were installed with a ¼-inch rubber insulating pad under the tie plate.

The track was unanchored. Ballast was crushed gravel (1- to 2-inch diameter) with some locations clogged by grease and mud (photos 7 and 8).



Photo 7. Ties, tie plates, track spikes and ballast



Photo 8. Closer view of tie, tie plate, track spikes and ballast

Train speed was restricted to a maximum of 10 mph. The track was considered “other than main track” but maintenance requirements were in accordance with Class 1 of the *Railway Track Safety Rules* (TSR) dated 03 November 2008 (TC E-31) approved by TC.

Examination of Track Components

Several of the 10-inch tie plates and round spikes from Track 22 (Photo 9) were sent to the TSB Laboratory (Report LP 099/2012). It was determined that:

- For the round track spikes, the shanks were corroded just below the head where the spikes came into contact with the tie plates. The diameters of the spikes were reduced by up to $\frac{5}{16}$ inch.
- The spike holes in the tie plates were enlarged by up to $\frac{1}{4}$ inch.
- The base of the 10-inch tie plates was approximately 50% thinner than the base of the 14-inch tie plates.



Photo 9. Older style tie plate and round track spikes

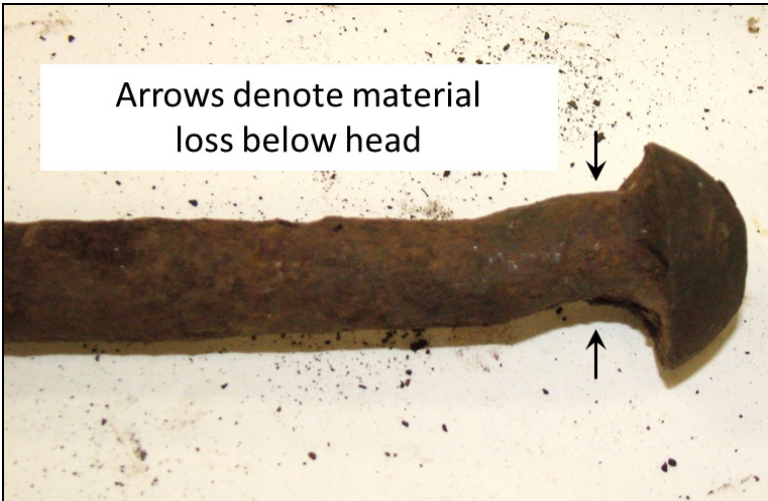

Photo 10. Round track spike showing material loss below spike head

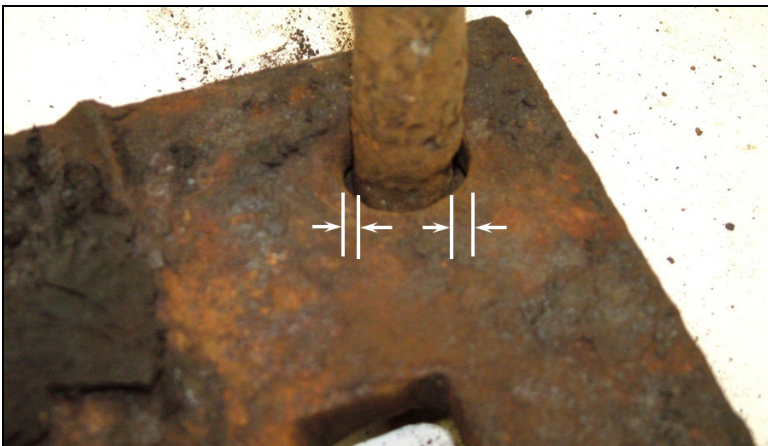

Photo 11. The spike hole in the tie plate is enlarged by up to $\frac{1}{4}$ inch

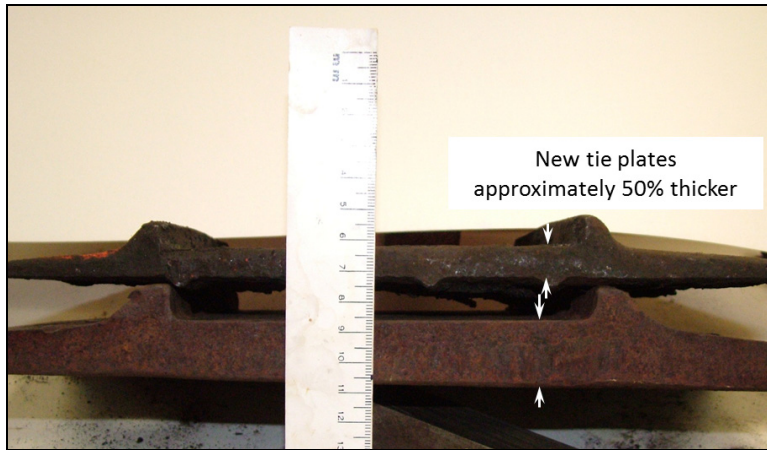

Photo 12. Older-style 10-inch tie plate superimposed on a new 14-inch tie plate; the base of the 10-inch tie plate is approximately 50% thinner than the base of the 14-inch tie plate.

The round track spikes have a head that covers the entire hole in the 10-inch tie plates, making it difficult to assess the wear and corrosion occurring on the shank of the spikes or the tie plate holes (Photo 13).



Photo 13. Top view of head of round track

Track Inspections

Track 22 had been inspected by hi-rail on 22 November 2011 and on 04 October 2011. No exceptions were noted in the derailment area. The TSR specify that “other than main track” must be inspected monthly, but do not require rail-flaw detection and track-geometry car-testing.

The track was last tested for rail flaws on 16 December 2010 and no exceptions were identified. The track was not tested by a track-geometry car.

Post-accident Track Measurements

Following the accident, track measurements for cross-level and gauge were obtained for 15 stations (measured 15 feet 6 inches apart) starting east of the derailed equipment (Appendix B):

- The measured gauge in unloaded conditions was approximately 57 $\frac{1}{4}$ inches, which was within the TSR-Class-1-track allowable limit of 58 inches.
- As specified in the CN Engineering Track Standards,⁹ 12° curves are designed with $\frac{1}{2}$ -inch superelevation for trains operating at 10 mph. The measured cross-level¹⁰ on the curve fluctuated between -1 $\frac{1}{4}$ inches to + $\frac{5}{8}$ inch, with the negative values occurring at the 3 stations at the end of the curve. The cross-level deviations from designed elevations were within the TSR allowed limits of 3 inches in curves for Class 1 track.

⁹ CN Engineering Track Standards, Table 1, June 2011.

¹⁰ Cross-level is the difference in elevation, in mm or inches, between the 2 rails, measured with a level board.

Critical Rail Gauge

When the loaded gauge exceeds the critical gauge limit of 59 inches defined by the physical dimension of a standard worn freight car wheel set, wheel drop will occur (Figure 4).

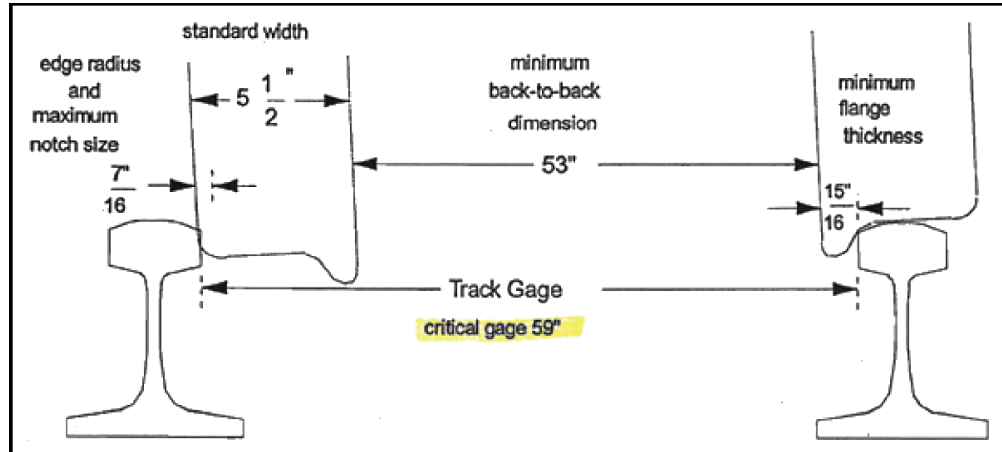

Figure 4. Critical gauge for standard worn wheel set (Source: Volpe National Transportation Systems Center)

For the ALP-45DP locomotive, equipped with new wheel sets, the critical rail gauge would be $59 \frac{1}{2}$ inches.

Lateral/Vertical Ratio

L/V quantifies the ratio between the force of the wheel flange pushing out on the rail (lateral force) and the wheel load of the equipment bearing down on the rail (vertical force). The single wheel L/V ratio can be used to predict the risk of a wheel climbing the gauge face of the rail or lifting off the rail (Figure 5). Similarly, the combined forces for the wheels on one truck side exerting high lateral forces onto the same rail can cause rail-head deflection, reverse-rail cant, or lateral-rail displacement, resulting in gauge spread or rollover. AAR guidelines indicate that truck side L/V values should not exceed 0.6.

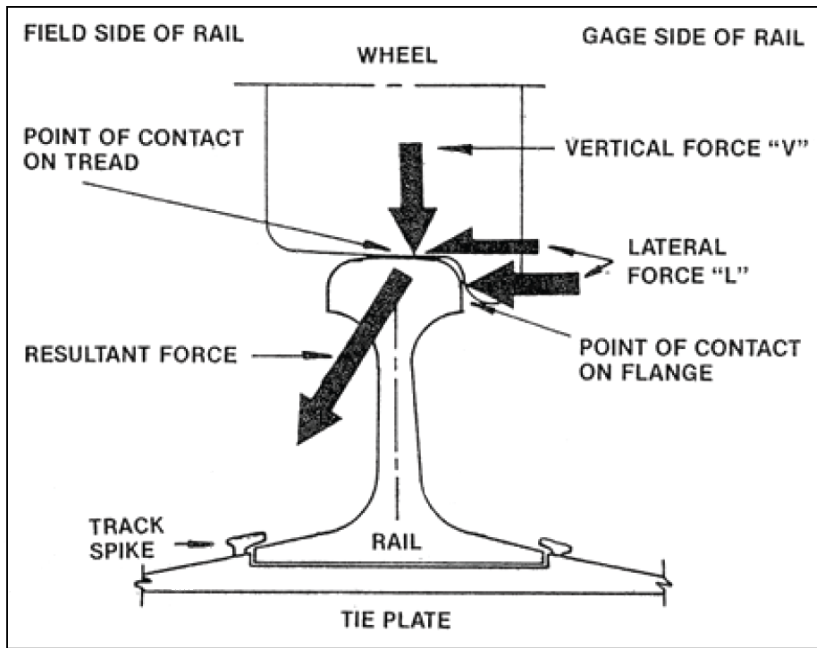

Figure 5. Forces between rail and wheel (Source: AAR)

Instrumented Tests

Following the accident, independent tests were conducted in Montréal and in New Jersey to assess the lateral forces being exerted into the track by the new dual-powered locomotives.

The Montréal tests were conducted by TUV Rheinland Rail Sciences (TUV/RSI), a Scottdale, Georgia-based railroad consulting firm. Two instrumented wayside sites equipped with strain gauges were installed to compare the lateral forces exerted on the track by 2 different types of locomotives. The low-speed tests were performed on 24 March 2012, in the derailment curve at Central Station. The higher-speed tests were performed on 31 March 2012 in a 3° curve in main track on the CN Deux-Montagnes Subdivision.

Two train consists were used. One train was equipped with the new dual-powered locomotives (ALP-45DP) and the other was equipped with the previously used style of locomotive that is, F40-PH manufactured by General Motors Electromotive Division. The results of the instrumented wayside tests are summarized as follows:

Table 2. Comparison of locomotives during instrumented wayside tests

	Central Station - Track 22		Mile 16.5, Deux-Montagnes Sub	
Locomotive type	ALP-45DP	F40-PH	ALP-45DP	F40-PH
Max. lateral wheel load	25 kips	20 kips	20 kips	20 kips

Max. truck side L/V ratio	0.32	0.21	0.30	0.52 ¹¹
----------------------------------	------	------	------	--------------------

Data source: TUV/RSI

The New Jersey tests were conducted by Prose Ltd., a Switzerland-based engineering company. Strain gauges were installed directly on the wheels on the lead truck of an ALP-45DP dual-powered locomotive that travelled over numerous yard-track and main-track locations throughout the NJ Transit system between 16 and 23 April 2012. Testing was also carried out on the Bayhead Loop, which had an 8° to 12° curve, with a superelevation of approximately 2 ½ inches. In comparison, Track 22 at Central Station has a maximum curvature of 11.75°. The results of the instrumented wheel-load testing for the Bayhead Loop track are summarized as follows:

Table 3. Instrumented wheel load testing of ALP-45DP locomotive

ALP-45DP	Run 1	Run 2
Max. laterals	23 kips	19 kips
Max. truckside L/V ratio	0.21	0.18

Data source: Prose Ltd.

Computer Simulations

Computer simulations using Track 22 data were performed by TUV/RSI to compare the ALP-45DP with other passenger-locomotive types used in Central Station by Amtrak and VIA. The results showed:

Table 4. Computer simulations using Track 22 data

Locomotive type	Wheel taper	Axle load	Lateral force
ALP-45DP	1:40	71 380 pounds	22.4 kips
ALP-45DP	1:20	71 380 pounds	20.4 kips
F40-PH (AMT 287)	1:20	65 500 pounds	16.7 kips
F40-PH (AMT 243)	1:20	65 500 pounds	21.6 kips
P42-DC (Genesis)	1:40	67 000 pounds	19.8 kips

Source: TUV/RSI

Gauge Restraint Measurement

A gauge restraint measurement system (GRMS) uses hydraulic pressure to apply lateral load outward to each rail. The equipment can be mounted on a dedicated rail car or on a hi-rail vehicle so that testing can be conducted in a dynamic environment while the equipment proceeds along the track. Hand-held testing equipment is also available for static testing in isolated locations.

¹¹ This maximum truck side L/V ratio was measured on the trailing truck of the lead locomotive and was considered to be a result of a worn but not condemnable wheel profile. The average ratio for that truck was 0.39. The L/V ratios of the leading truck averaged 0.30.

GRMS systems can apply a range of vertical loads to the rail to suit the circumstances, while maintaining an L/V ratio of approximately 0.7. To avoid any influence from adjacent wheel loads, design requirements specify that the unloaded track gauge must be measured at a point no less than 10 feet from any lateral or vertical load application. The applied vertical and lateral loads, as well as precise gauge measurements, are recorded.

Testing has shown that the relationship between applied load and rail-head deflection is predictive. The system continually measures lateral-rail deflection under these load conditions using algorithms to identify areas where rail-head deflection indicates a weak area. Track maintenance forces can then examine the identified areas to improve the rail-securement conditions (for example, ties, tie plates, anchors, and fastenings). Gauge restraint measuring is not a requirement under the TSR and is not a widespread industry practice in station tracks.

Effect of Lateral Forces on Rail-head Deflection

Testing sponsored by the United States Federal Railroad Administration ¹² assessed the amount of rail-head displacement under various loads for different track conditions. For example, the application of a vertical load of 15 000 pounds and a lateral load of 10 000 pounds ($L/V = 0.66$) will result in rail-head displacements between $\frac{1}{8}$ inch and $1 \frac{1}{4}$ inches, depending on tie conditions (Figure 6).

¹² A. Kish, D. Jeong, and D. Dzwonczyk, *Experimental Investigation of Gauge Widening and Rail Restraint Characteristics*, November 1984.

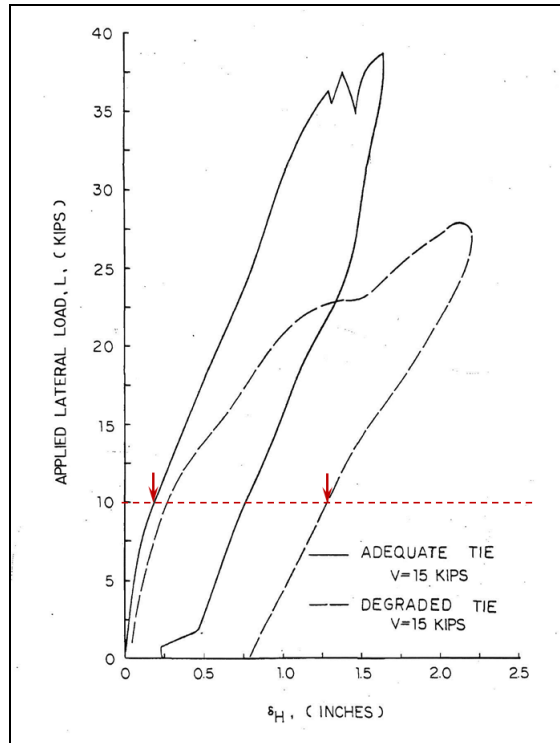

Figure 6. Rail-head deflection under lateral force based on tie conditions (Source: FRA, annotated by TSB)

Testing also showed that rail-head deflection is relatively insensitive to the size (weight) of rail. However, head-free rail, due to its lower-lateral stiffness, has more head deflection than other types of rail. With vertical loads of 30 kips, L/V values of 0.7 generate lateral loads of 21 kips, which can cause rail-head deflections of approximately 1 inch (Figure 7).

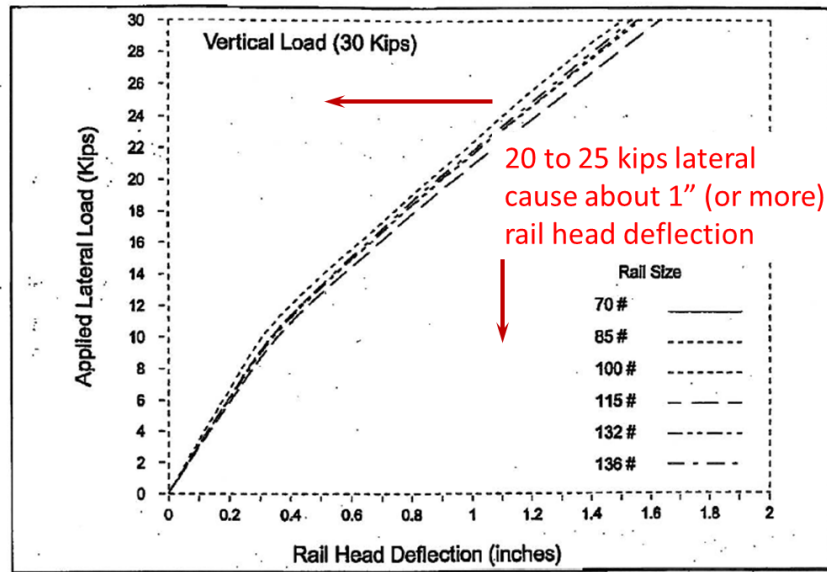

Figure 7. Rail-head deflection versus applied lateral load on various rail sizes when vertical load equals 30 kips (Source: FRA, annotated by TSB)

Effect of Wheel Contact on Rail Stability

Under lateral loads applied by the wheels, the rail rotates around the field side of the base. The lateral stability of a rail is linked to the b/h ratio between its height and the distance of the application of the wheel load to the field side of the base (Figure 8). Under equilibrium conditions, just before the rail starts to roll, the L/V ratio is equal to b/h .

In normal circumstances, the wheel-to-rail contact surface occurs at the inner gauge corner of the rail head. When the wheel load is shifted towards the field side, b decreases and b/h decreases. Therefore, L/V is also reduced, leading to an increased risk of rail rollover. The b/h ratio can vary from above 0.6 for contact at the gauge side, to approximately 0.2 when the contact surface is at the far-field side.

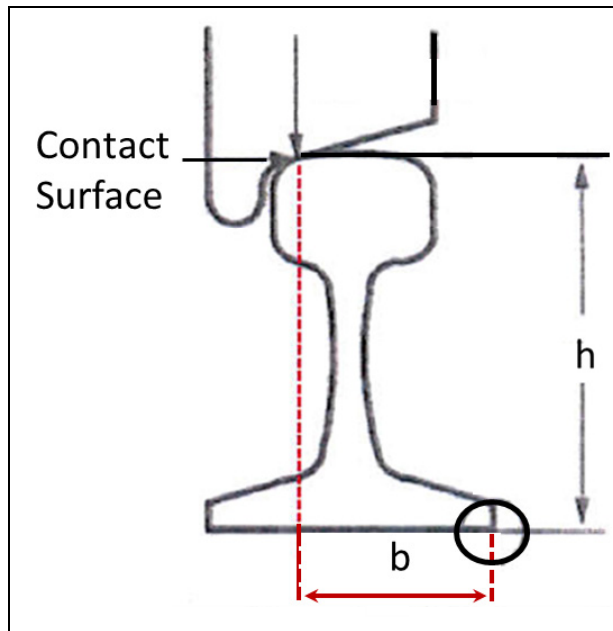

Figure 8. Rail stability diagram (Source: TUV/RSI)

The wheel profiles from locomotive AMT 1352 were compared to the actual rail profiles. Figure 9 identifies the wheel-rail contact points.

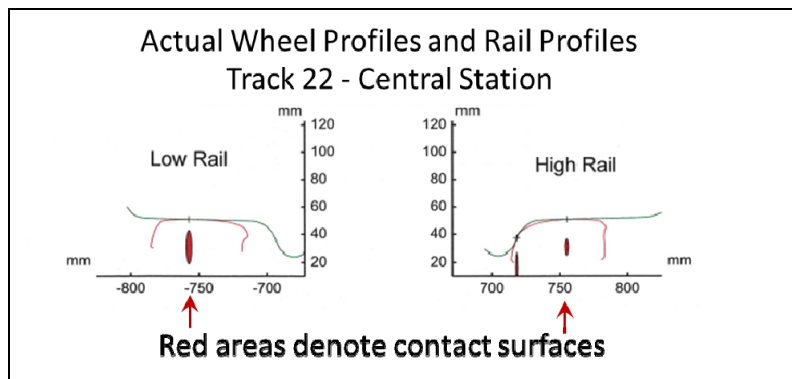

Figure 9. Location of lead locomotive wheel contact on rail head for Track 22 (Source: TUV/RSI)

Due to the location of the wheel/rail contact points that is, towards the field side of the rail, the b/h values were calculated to be approximately 0.45.

Broken Spikes from Track 21

After the accident, Track 21 underwent an inspection, as it had also been used by the ALP-45DP dual-powered locomotives. It was noted that there were several broken track spikes in the curved portion of the track at the eastern approach to the boarding platform. The head of the spikes had completely separated from the shanks. Some of the fracture surfaces on these spikes

were shiny. Others showed various degrees of oxidation (Photo 14). Examination of these spikes at the TSB Laboratory (Report LP 003/2012) determined that:

- the spikes did not break at the same height;
- the broken spikes failed in fatigue;
- the fatigue cracks varied by their age; and
- the shiny surfaces of the spikes, deformation, and fatigue cracks suggest that there was some significant relative movement of the spikes and tie plates.



Photo 14. Track 21 broken track spikes

The following TSB Laboratory reports were completed:

- LP 003/2012 – *Joint Bar and Spike Examination*
- LP 099/2012 – *Tie Plate and Track Spike Examination*

Analysis

There was nothing unusual noted with train handling. The analysis will focus on the rolling stock equipment that is, locomotive AMT 1352, the track conditions, related track maintenance and inspection practices, and track-safety standards.

The Accident

As the train approached the platform and negotiated the 11.75° curve, the leading truck of locomotive AMT 1352 exerted lateral forces on the north rail due to steering. These forces, amplified by the geometry characteristics of the curve, that is absence of superelevation and negative cross-level, deflected the rail head and widened the gauge. The resistance of the track to gauge widening was reduced and could not sustain the forces exerted by the leading truck because of the gauge-restraint conditions at the end of the curve, that is, wear and corrosion of the round track spikes, enlarged tie-plate holes, gap between the rail base and tie-plate shoulders, and the lower stiffness of the head-free rail. Once the critical gauge of 59 ½ inches was reached, the derailment occurred. The position of the derailed wheels, the marks on the splice bar, and the lateral shift of the south rail were consistent with a wheel drop-in on the south side.

Equipment Characteristics

The railways were aware that the gross vehicle weight of the dual-powered locomotive was approximately 7% heavier than the previously used type of locomotives. The heavier weight of the locomotive and the flatter wheel taper of 1:40 contributed to higher wheel loads being transmitted to the track structure. The length of the wheel base (110 inches) had a positive effect of distributing truck side forces on the rail. However, the hold-down effect that adjacent wheel loads can have to minimize gauge widening was negatively affected.

The vertical loads being transmitted to the track structure were similar to other heavy-freight equipment that was commonly accepted on most main-track areas, namely 286 000 pounds gross weight. In comparison with the F40-PH, the ALP-45DP locomotive generated higher lateral forces, and although the lateral forces were up to 25% higher, the L/V values were well within industry and regulatory norms and should not have posed a risk of rail rollover.

Geometry of the Curve

The absence of superelevation and the existence of a negative cross-level at the end of the curve were within permissible company and regulatory requirements, that is which allowed up to 3 inches of underbalance. However, these conditions shifted the weight of the locomotive to the outside of the curve and increased the lateral load on the north rail. The lateral load on the rail was also increased by the loss of wheel set steering in the curve caused by the contour of the curved rail and the new locomotive wheels. The wheel-rail contact surface was shifted towards the field side, that is, reduction in the b/h ratio, which resulted in a lower lateral stability of the rail. Furthermore, at the end of the curve, the rail type had changed to head-free rail. Given the

lower lateral stability and reduced torsional rigidity of the head-free rail, the ability of the rail to withstand rail-head displacement and reverse-rail cant was reduced.

Gauge-restraint Conditions

At the end of the curve, the measured gauge for unloaded conditions was approximately 57 ¼ inches. However, because of the condition of the rail securement, such as the wear and corrosion of the round track spikes, the enlarged tie-plate holes and the gap between the rail base and tie-plate shoulders, the track gauge could reach 57 15/16 inches, even under a relatively low lateral load. Given that the spikes on the north rail were lifted, some rail roll had occurred. The amount of spike lift (up to 1 inch) would have translated into a rail-head displacement of over 1 inch, thus approaching the critical gauge value of 59 ½ inches, resulting in the wheel drop.

Track-inspection Practices

The track had received visual inspections. However, the reduced lateral strength of the track was not detected. This visual inspection process relied primarily on the identification of track lateral-strength degradation such as the presence of wood checks or splits, visibly decayed ties, and the looseness of the tie plates and/or its spikes. However, in Central Station, many of the smaller tie plates were mounted on rubber pads that can mask tie-plate movement. In addition, the round track spikes covered the entire hole in the 10-inch tie plates, making it difficult to assess the wear and corrosion occurring on the shank of the spikes or the tie-plate holes. Furthermore, the visual track inspections were performed in relatively low-light-level conditions, which were not conducive to effective inspections.

Relying on visual-inspection methods alone to assess the extent to which track conditions affect the lateral strength of the track might not be sufficient as it is based on a subjective evaluation of the observed conditions. Since visual signs of lateral-track strength are not always fully assessed, and the inspection for lateral strength is a subjective process, there is an increased risk that the weakened lateral strength of some sections of track will remain undetected.

Assessing the track-lateral strength using technology such as GRMS, which applies lateral loads to the rails, would have been beneficial in identifying the track gauge restraint condition. GRMS is typically used in main-track locations, where speeds and tonnages are highest. This method of evaluation allows a quantitative assessment of tie conditions and addresses some of the shortcomings of visual inspection methods. However, passenger trains are not limited to main-track locations only. Therefore, for passenger trains that operate on tracks where railways do not use GRMS, there is a risk that the lateral strength of the track may not be adequately assessed.

The use of automated track-geometry measurements under load would also have been beneficial. As these measurements were not taken on Track 22, the opportunity to identify reverse-rail cant or negative cross-level conditions and their effect on gauge-widening forces by locomotives was lost.

Although the overall tie conditions met the requirements of Class 1 track, the condition of the rail-securement devices and their location in a cluster immediately before the point of derailment allowed further gauge-widening under load in the exit of the curve.

Track Safety Standards

For heavy equipment with vertical wheel loads in the range of 35 kips, the industry-acceptable L/V ratios produce lateral loads in the range of 20 to 25 kips, as was the case with locomotive AMT 1352. The FRA studies showed that lateral loads ranging from 20 to 25 kips can produce rail-head deflections of up to 1 inch depending on the tie conditions. The studies also determined that lateral loads do not decrease significantly even when the rail equipment is operated at speeds below 25 mph. Given that the TSR allows up to 1 ½ inches of wide gauge on Class 1 track, equipment with heavy wheel loads operating on curves with gauge approaching those limits could result in gauge widening to the point of reaching the critical gauge condition of 59 inches for standard worn wheels.

Track 21 Spikes

The track spikes from Track 21 had failed due to fatigue and the failures had likely occurred before the introduction of the new AMT locomotives.

Conclusions

Findings as to Causes and Contributing Factors

1. The absence of superelevation and the presence of negative cross-level at the exit of the curve resulted in an increase in the lateral wheel forces.
2. Locomotive AMT 1352 generated high lateral wheel forces, which contributed to the destabilisation of the rail, even though the L/V ratio was within industry and regulatory norms.
3. The derailment occurred when a wheel of locomotive AMT 1352, a new dual-powered locomotive, dropped inside the south rail at the exit of the 11.75° curve on Track 22 due to high lateral wheel forces and existing track gauge restraint conditions.

Findings as to Risk

1. Reducing train speed below 25 mph does not provide a safety defence to protect against equipment generating high lateral wheel loads as lateral wheel load is insensitive to speed below that value.
2. Given that the *Railway Track Safety Rules* (TSR) allow up to 1 ½ inches of wide gauge on Class 1 track, equipment with heavy wheel loads operating on curves with gauge

approaching those limits could result in gauge widening to the point of reaching the critical gauge condition of 59 inches for standard worn wheels.

3. In the absence of automated track geometry measurements under load and gauge restraint measurement system (GRMS) inspection, reverse rail cant or negative cross-level conditions and weak lateral-track strength are difficult to identify when employing visual inspection only, increasing the risk that track gauge widening will occur, leading to derailments.

Other Finding

1. The track spikes from Track 21 had failed due to fatigue and the failures had likely occurred before the introduction of the new AMT locomotives.

Safety Action

Canadian National

Immediately after the accident, Canadian National (CN) increased the frequency of visual-track inspections at Central Station from once a month to once a week. CN also repaired and upgraded tracks 19 through 22, by installing new tie plates with double shoulders and elastic fasteners on every second tie.

Transportation Safety Board

On 05 April 2012, the TSB issued Rail Safety Information letter (RSI-05/12) entitled *Condition of Track 22 at Montréal's Central Station, Quebec*. The letter noted that, although tracks 19 through 22 had undergone repairs and upgrades, some of the new tie plates were anchored to the ties with lag screws, which had damaged many of the ties by causing them to split. The railway subsequently advised that the damaged ties will be replaced during the winter of 2012.

Transport Canada

Transport Canada (TC) inspected the repaired tracks after the accident and determined that their tie conditions met the *Track Safety Rules* (TSR) for Class 1 track. Transport Canada stated that there was however a concern for the medium- to long-term condition of the damaged track ties. CN provided a maintenance plan related to the track ties on tracks 19 through 22 and TC is monitoring the railway's maintenance activities until all the damaged ties are replaced.

The TSR were revised (25 May 2012 - TC E-54). In the case of Class 1 track where passenger trains are operated, visual inspections must be done weekly or before use of passenger traffic if the track is used less than once a week, instead of monthly as prescribed in the previous TSR for non-main track.

Agence Métropolitaine de Transport

Agence Métropolitaine de Transport (AMT) has launched several initiatives to reduce the lateral curving forces on the new ALP-45DP locomotives. The wheel treads will be reprofiled to a 1:20 taper by the end of 2012 which, according to computer simulations, will reduce lateral curving forces in Central Station by approximately 9%. AMT and Bombardier Transportation have also committed to install within 12 months truck-mounted wheel lubricators to improve the wheel-to-rail coefficient of friction. AMT anticipates that the use of wheel lubricators will further reduce lateral curving forces in Central Station between 7% and 35%. Furthermore, computer simulations are being performed to assess the ALP-45DP locomotives against the Association of American Railroads (AAR) freight car Manual of Standards and Recommended Practices, Specification M-1001, Chapter XI.

Safety Concern

The installation of truck-mounted wheel lubricators and reprofiled 1:20 wheel tapers will reduce the lateral forces exerted by the new ALP-45DP locomotives. The reduced forces should be closer to the F40-PH locomotives presently used by AMT. However, an increasing number of passenger locomotives, such as the P42-DC and the PL-42, used by Amtrak, VIA Rail Canada Inc. and New Jersey Transit, are heavier than the F40-PH. They have comparable weights to the ALP-45DP, and can generate high lateral loads.

These heavier locomotives generate vertical wheel loads in the range of 30 to 35 kips and can exert lateral loads in the range of 20 to 25 kips on curves. Although this equipment meets the L/V ratio, Federal Railroad Administration (FRA) studies have demonstrated that lateral loads of this magnitude can produce rail head deflections of up to 1 inch.

There are numerous movements daily across Canada involving these heavy passenger locomotives on Class 1 track and yard tracks. Although the new TSR requirements will increase the type and frequency of certain inspections for some of these tracks, there are still no requirements to perform instrumented inspections on tracks such as Central Station tracks, where tonnage traffic is less than 5 million gross tons per mile (MGTM), using technology such as track-geometry cars or the gauge restraint measurement system (GRMS).

In these locations, the main defence to ensure that track conditions meet the TSR requirements is visual inspection. Relying on visual inspection methods alone to assess the extent to which track conditions affect the lateral strength of the track may not be sufficient as it is based on a subjective evaluation of the observed conditions. As the requirements for these sections of track are not as stringent as higher classes of track, there is an increased risk that low track lateral strength could be present and may go undetected.

Therefore, the Board is concerned that, where heavy passenger locomotives are operated on lower classes of track, adequate defences may not be in place to prevent excessive gauge widening, increasing the risk of derailments.

This report concludes the Transportation Safety Board's investigation into this occurrence. Consequently, the Board authorized the release of this report on 12 December 2012. It was officially released on 24 January 2013.

Visit the Transportation Safety Board's website (www.bst-tsb.gc.ca) for information about the Transportation Safety Board and its products and services. You will also find the Watchlist, which identifies the transportation safety issues that pose the greatest risk to Canadians. In each case, the TSB has found that actions taken to date are inadequate, and that industry and regulators need to take additional concrete measures to eliminate the risks.

Appendix A – Tie Requirements for Class 1 Track (Track Safety Rules)

Crossties

- (a) Crossties shall be made of a material to which rail can be securely fastened.
- (b) Each 39 foot segment of track shall have:
 - (1) a sufficient number of crossties which in combination provide effective support that will:
 - (i) hold gauge within the limits prescribed . . . ;
 - (ii) maintain surface within the limits prescribed . . . ; and
 - (iii) maintain alignment within the limits prescribed . . .
 - (2) the minimum number and type of crossties specified in paragraph(c) of this section effectively distributed to support the entire segment; and
 - (3) At least one crosstie of the type specified in paragraph (c) of this section that is located at a joint location as specified in paragraph (d) of this section.

- (c) Each 39 foot segment of:

Class 1 track shall have five crossties . . . which are not:

- (1) broken through;
- (2) split or otherwise impaired to the extent the crossties will allow the ballast to work through, or will not hold spikes or rail fasteners;
- (3) so deteriorated that the tie plate or base of rail can move laterally more than 1/2 inch relative to the crossties; or
- (4) cut by the tie plate through more than 40 per cent of a tie's thickness.

Appendix B – Post-accident Track 22 Measurements

Station # (15'6" c/c)	Chainage (ft)	Alignment Mid- Ordinate (62' chord)	Gauge	Unloaded X-Level	Curvature (degree)	Radius (R=50/Sin(D°/2))
Switch point	0					
0	76		56 7/8"	0"		
1	91		56 1/2"	0"		
2	107	1 1/4"	56 1/2"	+ 1/4"	1° 15'	4583.75' = 1397.13 m
3	122		56 5/8"	+ 1/2"		
4	138	5 1/2"	56 1/2"	+ 5/8"	5° 30'	1042.14' = 317.64 m
5	153		56 5/8"	+ 5/8"		
6	169	11"	57"	0"	11°	521.67' = 159.01 m
7	184		56 3/4"	+ 1/8"		
8	200	8 1/4"	56 5/8"	+ 1/4"	8° 15'	695.09' = 211.86 m
9	215		56 5/8"	+ 1/4"		
10	231		56 3/4"	0"		
11	246		57 1/8"	0"		
12	262		57 1/4"	0"		
13	277		56 3/4"	+ 1/4"		
14	293		56 3/4"	+ 1/8"		
15	308		57 1/4"	+ 1/8"		
16	324		56 3/4"	(- 1/2")		
17	339		56 5/8"	(- 3/8")		
18	355		56 7/8"	(- 1 1/4")		
19	370		58 1/8"	-		
20	386		n/r	-		
NOTE	Station No. 0 is located at the heel of frog (75.86' from switch point for Track 22 switch).					